

BILL OF MATERIAL

No.	SPECIFICATION	LENGTH (mm)	GRADE	QUANTITY	WEIGHT(Kg)		REMARKS
					UNIT	TOTAL	
B01-CL073 1 PCS. IN TOTAL							
B01-tp 008	FLT50*600	1195	S355JR	1	281.42	281.42	
B01-tp 332	FLT30*350	4430	S355JR	1	365.14	365.14	
B01-tp 344	FLT30*350	4430	S355JR	1	365.14	365.14	
B01-gp 177	PLT16*473.8	710	S355JR	1	34.45	34.45	
B01-gp 178	PLT16*701.7	710	S355JR	1	42.01	42.01	
B01-mp 047	PLT20*350	1095	S355JR	1	60.17	60.17	
B01-ef 111	PLT20*169	835	S355JR	4	22.12	88.48	
B01-ef 146	PLT25*250	600	S355JR	2	29.44	58.88	
B01-ef 149	PLT25*250	125	S355JR	10	3.04	30.44	
B01-ef 268	PLT12*100	100	S355JR	2	0.63	1.26	
B01-ef 298	PLT12*100	169	S355JR	4	1.02	4.08	
B01-ef 353	PLT25*250	294	S355JR	2	9.61	19.23	
B01-mp 303	PLT12*835	4430	S355JR	1	348.45	348.45	
TOTAL WEIGHT:					1699.149	*1 = 1699.15 Kg	

BOLT LIST FOR ASSEMBLY-B01-CL073 1 PIECE

DIA	GRADE	TYPE	LENGTH	NOS.	MEMBER
NOTES:					
1. ALL BUILT-UP PROFILES WELDS SHALL BE DOUBLE SIDE WELDING.					
2. REFER WELDING STANDARD DRAWING FOR WELD SIZE U.N.O.					
3. ALL TRUSS DIAGONAL & VERTICAL MEMBER WELDED WITH TOP & BOTTOM CHORD IS FPBW.					
4. WELD SIZE FOR HOT ROLLED PROFILE CONNECTION SHALL BE THICKNESS OF THINNER ELEMENT.					

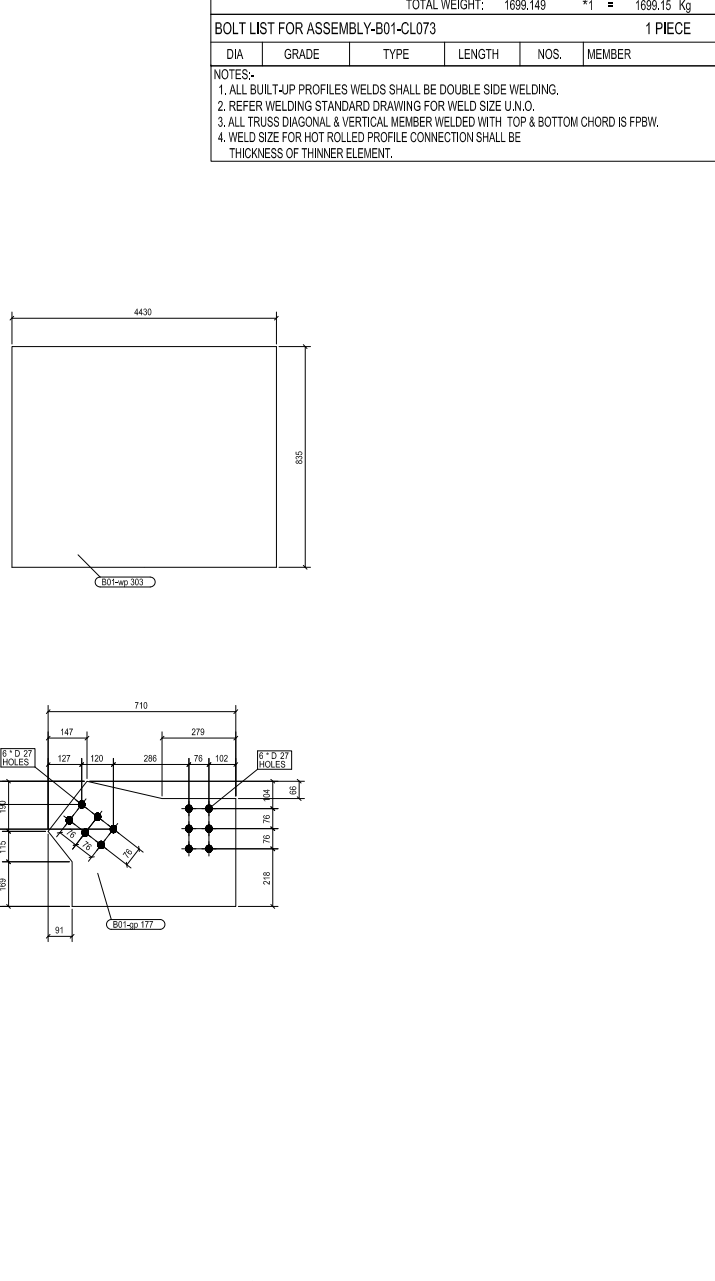
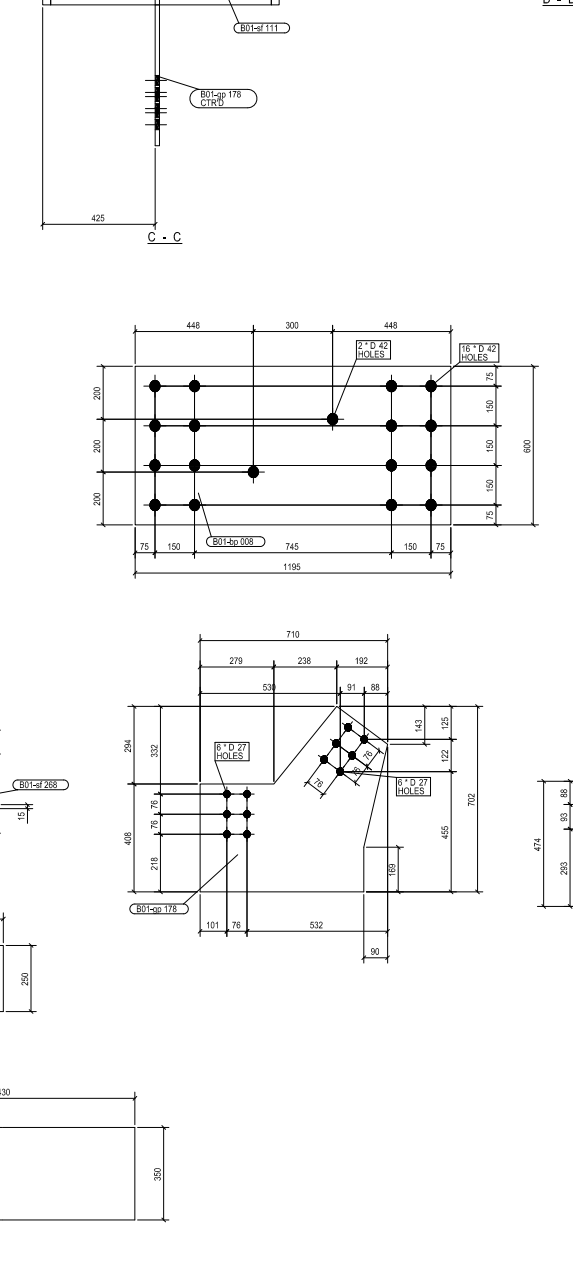
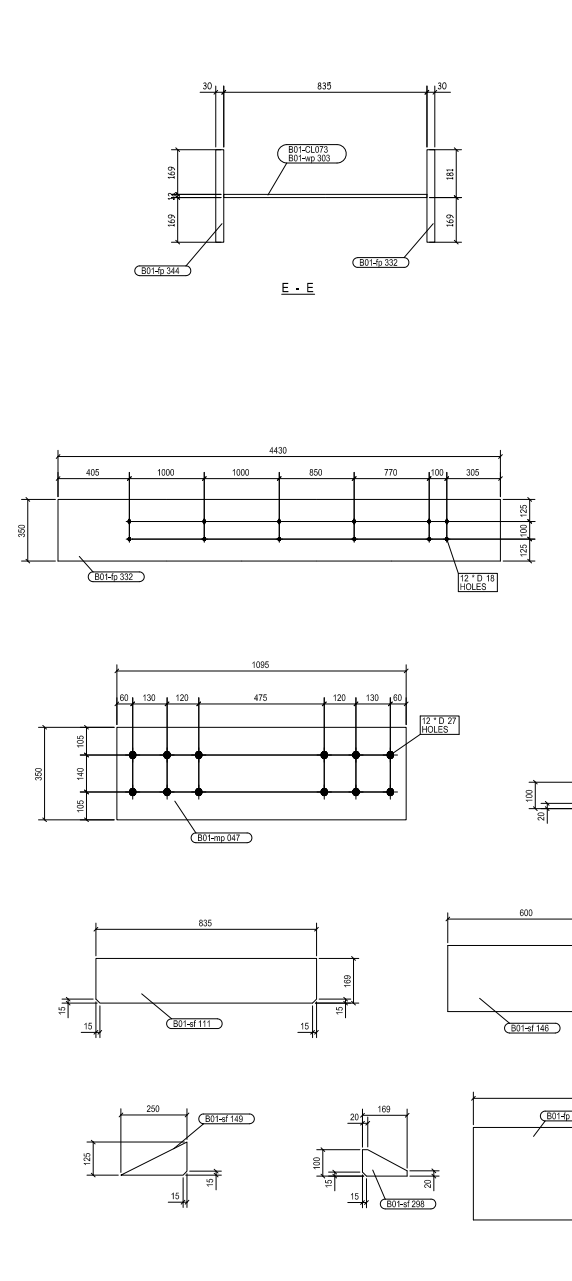
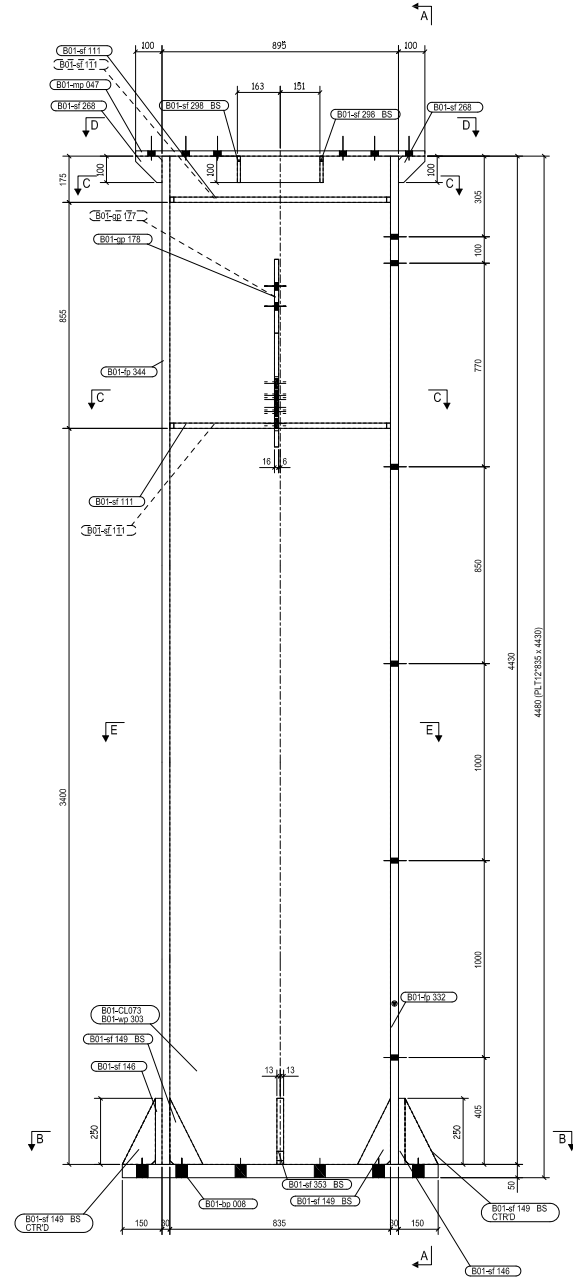
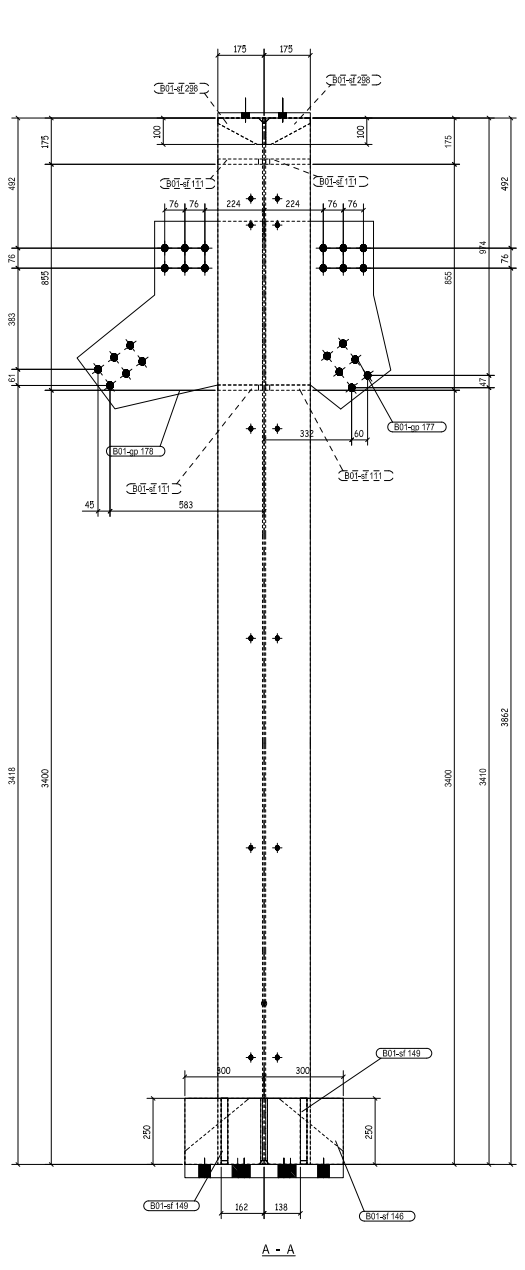

COLUMN - B01-CL073 - 1 No. Phase 101

PAINT NOTE :- FOLLOW APPROVED PAINTING MAR.

Phase	Qty.
101	1
G.Total =	1

Rev	DATE	DRN	CHK.	APP.	DESCRIPTION
CLIENT: MINISTRY OF EXTERNAL AFFAIRS (GOVT. OF INDIA)					
CONSULTANT:					
CONTRACTOR:					
STEEL CONTRACTOR:					
ASSEMBLY					SHEET 01 OF 02
JOB NO:	BLOG NO:	PHASE NO:	DRN BY:	CHK BY:	